

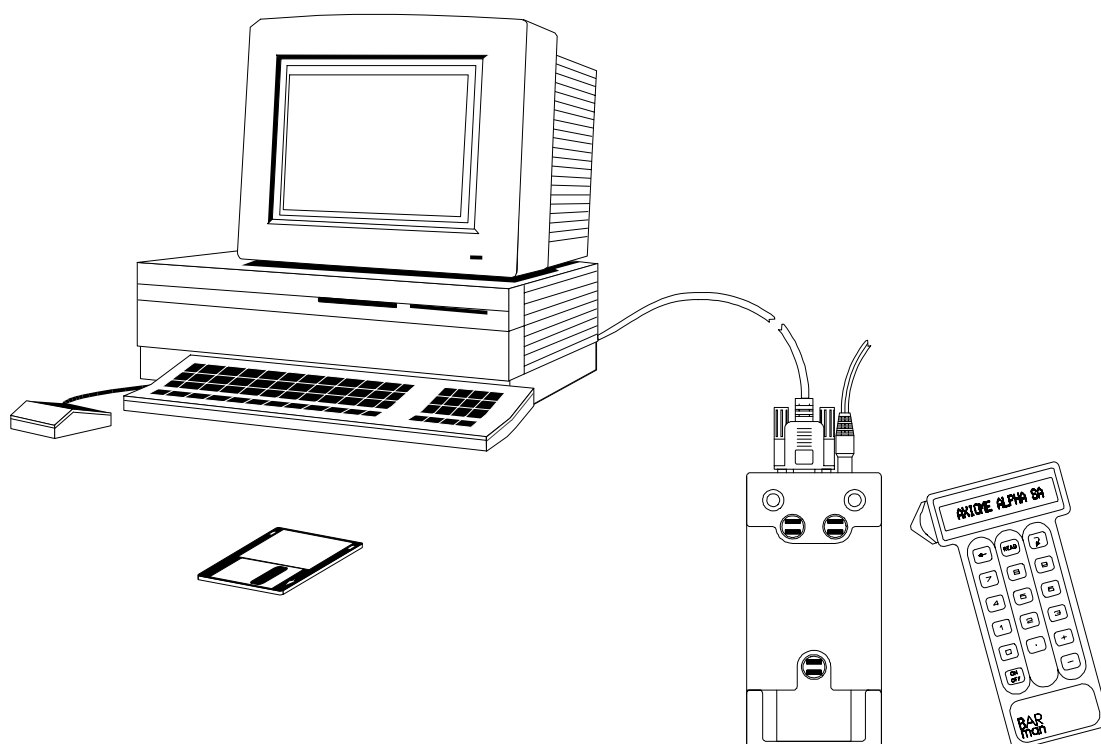

BARman ATL / STL
t. BARman TAG / TBC
User manual



What you need to use BARman :

- at least one BARman,
- at least one interface connected to the computer,
- a Personal computer,
- the AXIOME communication software.

| | |
|--|----|
| Chapter 1 : General description..... | 5 |
| 1.1. BARman system..... | 5 |
| 1.2. Operating manual..... | 5 |
| 1.3. BARman..... | 6 |
| 1.3.1. BARman Series 100 (numeric keypad)..... | 6 |
| 1.3.2. BARman Series 300 (alphanumeric keypad)..... | 7 |
| 1.3.3. Barcode reading head..... | 7 |
| 1.3.4. Battery..... | 7 |
| 1.4. t.BARman TAG..... | 8 |
| 1.4.1. t.BARman TAG Series 100 (numeric keypad)..... | 9 |
| 1.4.2. t.BARman TAG Series 300 (alphanumeric keypad)..... | 9 |
| 1.4.3. RFID reading head..... | 9 |
| 1.4.4. Battery..... | 10 |
| 1.5. t.BARman TBC..... | 10 |
| 1.5.1. t.BARman TBC Series 100 (numeric keypad)..... | 11 |
| 1.5.2. t.BARman TBC Series 300 (alphanumeric keypad)..... | 11 |
| 1.5.3. Reading heads..... | 11 |
| 1.5.4. Battery..... | 12 |
| 1.6. Interface unit..... | 12 |
| 1.7. BARman ATL / STL's and t.BARman TAG / TBC's firmware..... | 13 |
| 1.8. Firmware special functions..... | 13 |
| 1.8.1. Menu of the BARman ATL/STL and t.BARman TAG/TBC..... | 14 |
| 1.8.2. Message..... | 15 |
| 1.8.3. User name..... | 15 |
| 1.8.4. Time..... | 15 |
| 1.8.5. Date..... | 16 |
| 1.8.6. Memory free space..... | 16 |
| 1.8.7. Terminal status..... | 16 |
| 1.8.8. Active barcode decoder..... | 16 |
| 1.8.9. Battery state..... | 17 |
| 1.8.10. Terminal's number..... | 17 |
| 1.8.11. Firmware version..... | 18 |
| 1.8.12. Print..... | 18 |
| 1.9. Programming software..... | 19 |
| 1.10. Communication software..... | 19 |
| 1.10.1. AXS communication software for MS-DOS..... | 19 |
| 1.10.2. BARCOM for Windows (32 bits application)..... | 20 |
| 1.10.3. BARmanager for Windows (16 bits application)..... | 20 |
| 1.10.4. DDEServer for Windows (16 bits application)..... | 20 |
| 1.10.5. BAROLE for Windows (32 bits application)..... | 20 |
| Chapter 2 : Maintenance..... | 21 |
| 2.1. Terminal's maintenance..... | 21 |
| 2.2. " Left-handed " reading heads..... | 21 |
| Chapter 3 : Troubleshooting..... | 23 |
| 3.1. Error messages in BARman..... | 23 |
| Chapter 4 : Hard Reset..... | 25 |
| 4.1. Terminal's Hard Reset..... | 25 |
| 4.2. Firmware transfer under MS-DOS..... | 26 |
| 4.3. Firmware transfer under Windows..... | 26 |

| | |
|--|----|
| Appendix A: BARman ATL with 17 keys front (series 100)..... | 27 |
| Appendix B: BARman ATL with 34 keys front (series 300)..... | 28 |
| Appendix C: t.BARman TAG with 17 keys front (series 100)..... | 29 |
| Appendix D: t.BARman TAG with 34 keys front (series 300)..... | 30 |
| Appendix E: t.BARman TBC with 17 keys front (series 100) | 31 |
| Appendix F: t.BARman TBC with 34 keys front (series 300) | 32 |
| Appendix G: Terminal's back (series 100 & 300)..... | 33 |
| Appendix H: Table for Demo 6 and Demo 8 AXEL program..... | 34 |

TRADEMARK INFORMATION

BARman[®] is a registered trademark of Axiome Alpha SA.

MS-DOS[®] is a registered trademark of Microsoft Corporation.

Windows[®] is a registered trademark of Microsoft Corporation.

Convention: Under the denomination TERMINAL, we understand as well BARman ATL/STL as t.BARman TAG/TBC

Chapter 1 : General description

1.1. BARman system

The BARman ATL/STL and t.BARman TAG/TBC are an easy data collecting system composed of:

- a portable data entry device with its own clock (BARman ATL/STL or t.BARman TAG/TBC),
- an interface unit (BIU, BEI, IBS or CIU),
- a programming software (AXEL32 Extended),
- a communication software for DOS or Windows.

The terminal is designed to record dated information related to the user's daily activities which will be processed by a computer. The interface units and the communication software allows to transfer the terminal's data into the computer.

1.2. Operating manual

The operating manual is made up of eight volumes:

- Volume 1: **BARman ATL / STL and t.BARman TAG / TBC operating manual.**
Describes the BARman (pen), the t.BARman TAG/TBC and their firmware.
- Volume 2: **Interface operating manual.**
Describes the single (BEI, IBS, BIU, ILS) and multiple interfaces (CIU, ILM), installation and networking. This manual is delivered with each interface.
- Volume 3: **AXS communication software.**
Describes the communication software AXS for MS-DOS. This manual is delivered with the software package SDC310.
- Volume 4: **BARmanager user manual.**
Describes the communication software BARmanager for Windows. This manual is delivered with the software package SDP110.
- Volume 5: **AXEL32 Extended programming manual.**
The programming manual describes how to program BARman, BARman Laser and t.BARman using the AXEL32 Extended language. This manual is delivered with the software package SDP350.
- Volume 7: **BARman Laser user manual.**
Describes the BARman Laser TLL / LGA and their firmware AXEL_OS xx
- Volume 8: **C programming manual.**
The programming manual describes how to program BARman Laser using the C language. This manual is delivered with the software package SDP300.
- Volume 9: **t.BARman BTS / BTL operating manual.**
Describes the t.BARman BTS / BTL and their firmware BTS_OS xx / BTL_OS xx

1.3. BARman

BARman is a portable data entry terminal with an integrated bar-code reading head. It is designed to collect information related to the user's daily activities which will be processed later by a computer.

The BARman can be programmed for multitask applications (inventory management, quality control, time management, etc.); it can automatically add the date and time of day at each entry.

BARman : the intelligent data entry system that saves time and money and improves data reliability .

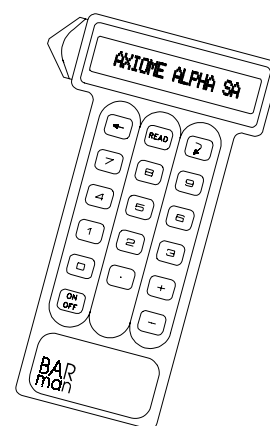

Some of BARman's feature:

- handy and lightweight (180 g)
- no plugs or sockets
- robust, ergonomic housing
- user-friendly menus (dialogue)
- reader head comes in left- and right-handed versions
- display of 16 alphanumeric characters
- keypads with 17 or 34 keys
- integrated clock and calendar
- clip attachment
- 128 KB memory

1.3.1. BARman Series 100 (numeric keypad)

The BARman ATL1xx / STL1xx has a keypad with 17 numeric keys.

Fold out Appendix A:, page 27 and Appendix G:, page 33 to locate the following elements:

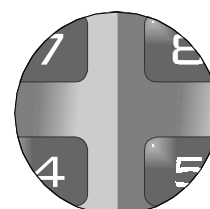

- 1: Reading head (available on model ATL only) and head cover, "nose" delivered in different colors.
- 2: LCD (16 alphanumeric characters).
- 3: 17 numeric keys
- 4: Label holder
- 5: Clip attachment
- 6: Magnetic contacts
- 7: Hard reset hole

1.3.2. BARman Series 300 (alphanumeric keypad)

The BARman ATL3xx / STL3xx has a keypad with 34 alphanumeric and function keys.

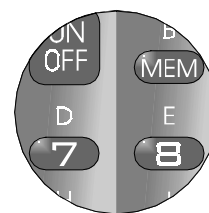

Fold out Appendix B:, page 28 and Appendix G:, page 33 to locate the following elements.

- 1: Reading head (available on model ATL only) and head cover, "nose" delivered in different colors.
- 2: LCD (16 alphanumeric characters).
- 3: 34 numeric keys
- 4: Label holder
- 5: Clip attachment
- 6: Magnetic contacts
- 7: Hard reset hole

1.3.3. Barcode reading head

The BARman ATL has an integrated barcode reading head with an interchangeable cover which comes in different colors.

The reading head is standardised for right-hand reading but can be changed to left-hand reading by an authorised dealer.

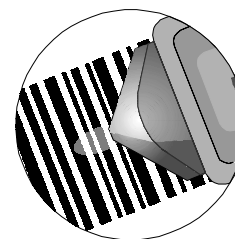

To read a barcode, glide BARman's nose over the code.

For maintenance see Chapter 2 :, page 21.

1.3.4. Battery

Each BARman has a long-life Ni-MH battery that is automatically recharged when BARman lies in its base station. BARman controls the charge of the batteries by increasing or decreasing the supply of current according to the state of charge of the batteries. It is possible to consult the state of charge of the batteries by using the "☐←" key as explained later on (refer to chapter 1.8.9).



Depending on the BARman model and on the frequency of use, the battery supplies enough power for:

- 4'500 barcode reading cycles for ATL120 and for ATL 320, or 2 weeks when used with the keypad (1 read /s).
- 13'500 bar code reading cycles for ATL 150 and for ATL 350 (1 read /s).
- Collected data are saved for up to 2 months.

Failure to charge, may destroy your data and the program.

Nevertheless it is advisable to recharge the battery regularly in order to maintain maximum autonomy. The BARman must in any case be charged for at least 6 hours each month.

If the battery is totally discharged, the BARman cannot download its firmware. Leave the BARman for one night on the single interface before carrying out the hard reset (see Chapter 4 ;, page 25).

The battery can be changed ONLY by an authorized dealer.

1.4. t.BARman TAG

t.BARman TAG is a portable data entry terminal with an integrated RFID head to read and write 125 kHz TAGS (transponders). It is designed to collect information related to the user's daily activities which will be processed later by a computer.

The t.BARman TAG can be programmed for multitask applications (inventory management, quality control, time management, etc.); it can automatically add the date and time of day at each entry.

t.BARman TAG : the intelligent data entry system that saves time and money and improves data reliability .

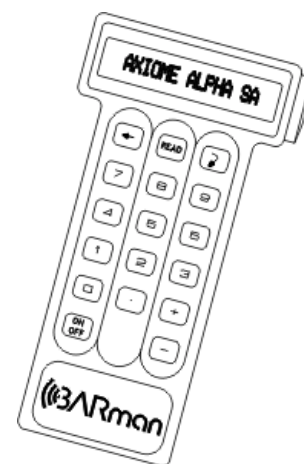

Some of t.BARman TAG's feature:

- handy and lightweight (180 g)
- no plugs or sockets
- robust, ergonomic housing
- user-friendly menus (dialogue)
- RFID head comes in left- and right-handed versions
- display of 16 alphanumeric characters
- keypads with 17 or 34 keys
- integrated clock and calendar
- clip attachment
- 128 KB memory

1.4.1. t.BARman TAG Series 100 (numeric keypad)

The t.BARman TAG1xx has a keypad with 17 numeric keys.

Fold out Appendix C:, page 29 and Appendix G:, page 33 to locate the following elements:

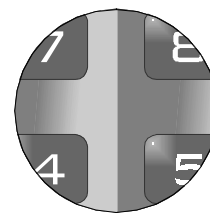

- 1: RFID reading / writing head.
- 2: LCD (16 alphanumeric characters).
- 3: 17 numeric keys
- 4: Label holder
- 5: Clip attachment
- 6: Magnetic contacts
- 7: Hard reset hole

1.4.2. t.BARman TAG Series 300 (alphanumeric keypad)

The t.BARman TAG3xx has a keypad with 34 alphanumeric and function keys.

Fold out Appendix D:, page 30 and Appendix G:, page 33 to locate the following elements.

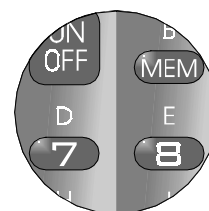

- 1: RFID reading / writing head.
- 2: LCD (16 alphanumeric characters).
- 3: 34 numeric keys
- 4: Label holder
- 5: Clip attachment
- 6: Magnetic contacts
- 7: Hard reset hole

1.4.3. RFID reading head

The t.BARman TAG has an integrated RFID reading / writing head. Two different type of RFID reading head are available, orange (TLT-1d) and blue (TLT-1e). Please refer to the table page 18, to see which head, which type of TAG can read.

The RFID reading / writing head is standardised for right-hand reading but can be changed to left-hand reading by an authorised dealer.



To read / write a TAG, simply approach the RFID head of the t.BARman TAG (approx. 2 cm) to the transponder.

For maintenance see Maintenance, page 21.

1.4.4. Battery

Each t.BARman TAG has a long-life Ni-MH battery that is automatically recharged when t.BARman TAG lies in its base station. t.BARman TAG controls the charge of the batteries by increasing or decreasing the supply of current according to the state of charge of the batteries. It is possible to consult the state of charge of the batteries by using the "☐←" key as explained later on (refer to chapter 1.8.9).

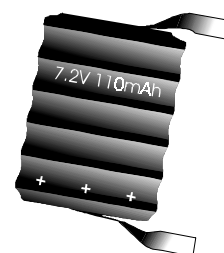

Depending on the frequency of use, the battery supplies enough power for:

- 4'000 TAG reading cycles, or 2 weeks when used with the keypad (1 read /s).
- Collected data are saved for up to 2 months.

Failure to charge, may destroy your data and the program.

Nevertheless it is advisable to recharge the battery regularly in order to maintain maximum autonomy. The t.BARman TAG must in any case be charged for at least 6 hours each month. If the battery is totally discharged, the t.BARman TAG cannot download its firmware. Leave the t.BARman TAG for one night on the single interface before carrying out the hard reset (see Chapter 4 :, page 25).

The battery can be changed ONLY by an authorized dealer.

1.5. t.BARman TBC

t.BARman TBC is a portable data entry terminal with an integrated barcode head and an integrated RFID head to read and write 125 kHz TAGS (transponders). It is designed to collect information related to the user's daily activities which will be processed later by a computer.

The t.BARman TBC can be programmed for multitask applications (inventory management, quality control, time management, etc.); it can automatically add the date and time of day at each entry.

t.BARman TBC : the intelligent data entry system that saves time and money and improves data reliability .

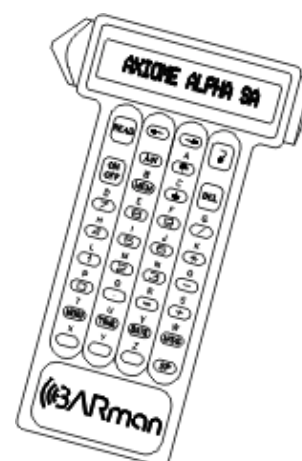

Some of t.BARman TBC's feature:

- handy and lightweight (180 g)
- no plugs or sockets
- robust, ergonomic housing
- user-friendly menus (dialogue)
- barcode and RFID head
- display of 16 alphanumeric characters
- keypads with 17 or 34 keys
- integrated clock and calendar
- clip attachment
- 128 KB memory

1.5.1. t.BARman TBC Series 100 (numeric keypad)

The t.BARman TBC1xx has a keypad with 17 numeric keys.

Fold out Appendix E:, page 31 and Appendix G:, page 33 to locate the following elements:

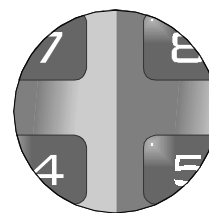

- 1a: RFID reading / writing head
- 1b: Barcode reading head and head cover, "nose" delivered in different colours.
- 2: LCD (16 alphanumeric characters).
- 3: 17 numeric keys
- 4: Label holder
- 5: Clip attachment
- 6: Magnetic contacts
- 7: Hard reset hole

1.5.2. t.BARman TBC Series 300 (alphanumeric keypad)

The t.BARman TBC3xx has a keypad with 34 alphanumeric and function keys.

Fold out Appendix F:, page 32 and Appendix G:, page 33 to locate the following elements.

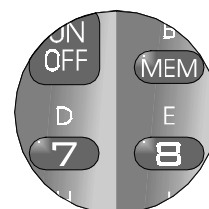

- 1a: RFID reading / writing head
- 1b: Barcode reading head and head cover, "nose" delivered in different colours.
- 2: LCD (16 alphanumeric characters).
- 3: 34 numeric keys
- 4: Label holder
- 5: Clip attachment
- 6: Magnetic contacts
- 7: Hard reset hole

1.5.3. Reading heads

The t.BARman TBC has an integrated barcode reading head with an interchangeable cover which comes in different colors as well as a RFID reading / writing head. Two different type of RFID reading / writing head are available, orange (TLT-1d) and blue (TLT-1e). Please refer to the table page 18 to see which head, which type of TAG can read.

The barcode reading head is standardised for right-hand reading but can be changed to left-hand reading by an authorised dealer.

To read a barcode, glide t.BARman TBC nose over the code.

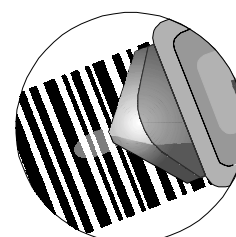

To read / write a TAG, simply approach the RFID head of the t.BARman TBC (approx. 2 cm) to the transponder.

For maintenance see Maintenance, page 21.

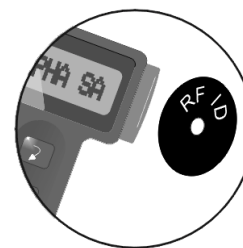

1.5.4. Battery

Each t.BARman TBC has a long-life Ni-MH battery that is automatically recharged when t.BARman TBC lies in its base station. t.BARman TBC controls the charge of the batteries by increasing or decreasing the supply of current according to the state of charge of the batteries. It is possible to consult the state of charge of the batteries by using the "☐←" key as explained later on (refer to chapter 1.8.9).

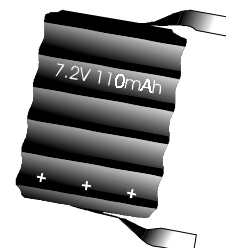

Depending on the frequency of use, the battery supplies enough power for:

- 4'000 barcode and TAG reading cycles, or 2 weeks when used with the keypad (1 read /s).
- Collected data are saved for up to 2 months.

Failure to charge, may destroy your data and the program.

Nevertheless it is advisable to recharge the battery regularly in order to maintain maximum autonomy. The t.BARman TBC must in any case be charged for at least 6 hours each month. If the battery is totally discharged, the t.BARman TBC cannot download its firmware. Leave the t.BARman TBC for one night on the single interface before carrying out the hard reset (see Chapter 4 :, page 25).

The battery can be changed **ONLY** by an authorized dealer.

1.6. Interface unit

The interface unit allows the terminal to communicate with a computer. The three magnetic contacts establish the connection. This exclusive system transfers data to and from a computer and recharges the battery at the same time.

The different interfaces and their installation instructions are described in volume 2: INTERFACES OPERATING MANUAL.

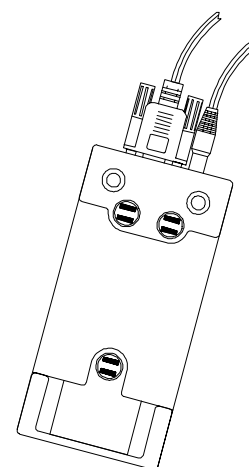

1.7. BARman ATL / STL's and t.BARman TAG / TBC's firmware

The firmware is the BARman ATL/STL's and t.BARman TAG/TBC's operating system. Without firmware, it is not possible to run the terminal. As the performance of terminal is modified from time to time to satisfy the needs of the market, a number indicates the firmware in use.

A firmware version is delivered with every communication software package, but you can always find the latest firmware version on our web site www.axiome.ch.

A new terminal always contains the latest firmware version.

From version 4.0 onwards, every upgrade is fully compatible with the oldest, it is always possible to run the same programs (subject to one condition only: that they have been recompiled with the corresponding compiler) if you upgrade the terminal and have the advantages of the new firmware.



The procedure for downloading new firmware into the terminal is described in each communication software package.

The firmware also includes a decoder module and the demo10 program (Read a barcode and read a TAG), so the terminal is immediately ready for barcode and/or TAG reading.

1.8. Firmware special functions

Regardless of the user's program, the BARman ATL/STL and the t.BARman TAG/TBC integrates a menu which allows consulting of different status.

This menu is divided in two parts, the main and the extended one.

To consult the menu, the terminal must be off. The  keys (for Serie 100) and  (for Serie 300) run the main menu and the  keys allows access to the extended menu.

1.8.1. Menu of the BARman ATL/STL and t.BARman TAG/TBC

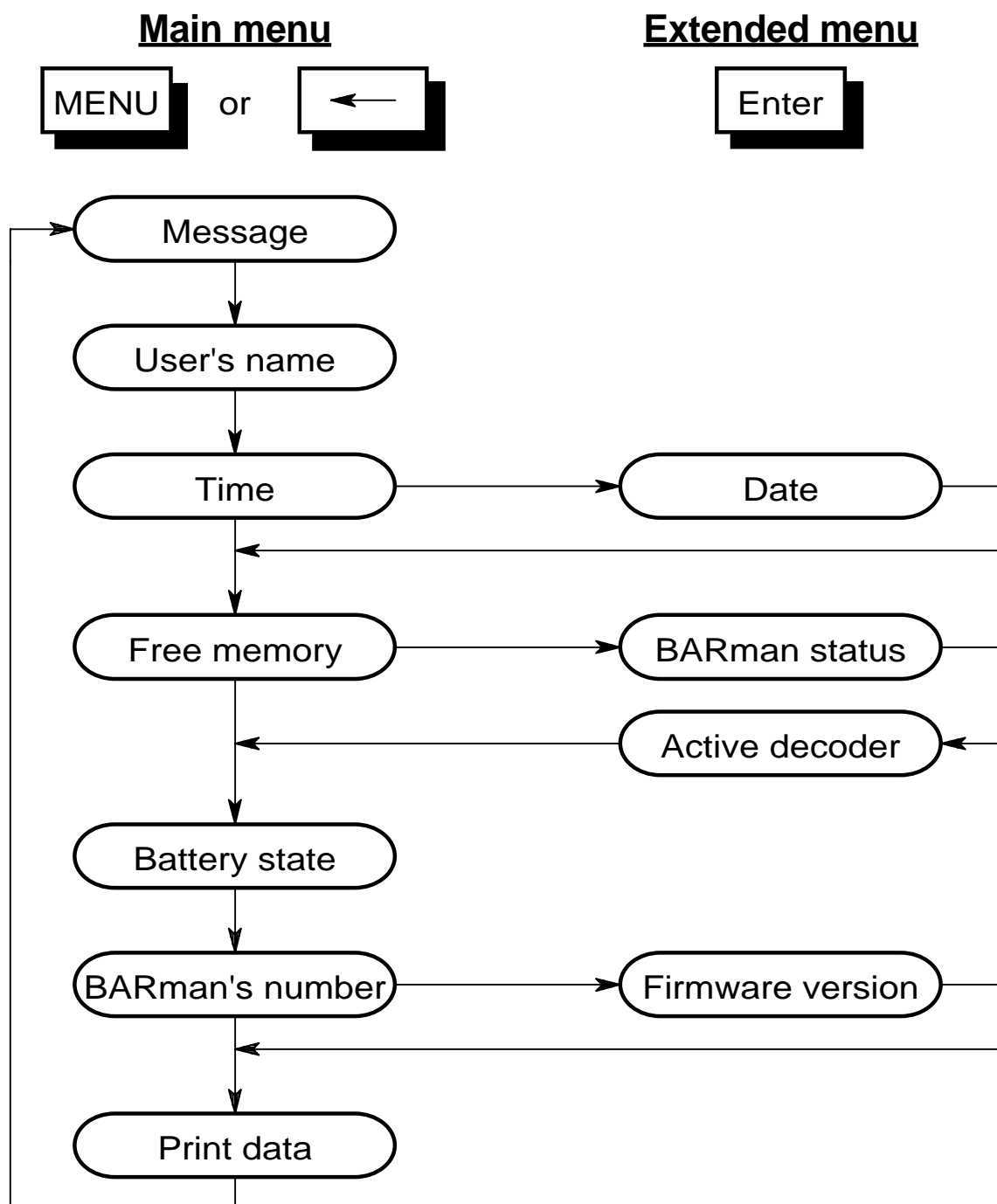

1.8.2. Message

```
Message (+/-) v
```

For consulting a message, use the "□+" and "□-" key.

When the terminal has been disconnected from its base station (BIU, BEI, IBS or CIU) and has received a message, the user is warned by a beep sound and "Message received" appears on the display.

The message can be consulted by activating the user's menu key (□←) or □MENU.

The first position on the menu shows : "Message (+/-)", pressing the □+ key causes the first words of the message to appear on the display.

Pressing the □+ key again causes the message to be displayed in entire words listed from left to right. Pressing the □- key gives the message in reverse.

When the end of the message is reached, the terminal asks : "Accept message ?". Pressing the □↓ key brings the confirmation that the message has been read by the user.

Please note that a message can be consulted at any time as long as the computer has not sent another message.

After a confirmation, the terminal can accept a new message which it will record over the previous one.

1.8.3. User name

```
** AXIOME ** _
```

Displays the user name of the terminal.

This name is also displayed when the terminal is connected on its base station.

Remark : If the last character is _, means that the terminal doesn't contain data.
If the last character is ■, means that the terminal contain datas.

1.8.4. Time

```
Time 16:55 v
```

Indicates the terminal's internal time.

1.8.5. Date

```
FR 03 AUG 2001
```

Indicates the terminal's internal date : day of the week, day, month and year.

1.8.6. Memory free space

```
Memory 87k free_
```

Indicates in Kbytes the quantity of free memory in the terminal.

Remark : One Kbyte allows to store 1024 characters.
If the last character is _, means that the terminal doesn't contain data.
If the last character is ■, means that the terminal contain datas.

1.8.7. Terminal status

```
BARman 128k Std
```

Indicates the size of the memory installed in the terminal and the kind of the barcode reading head.

Std : Standard reading head (ATL120 / 320 or ATL130 / 330 or TBC120 / 320)
Mod : Modulated reading head (ATL150 / 350 or STL150 / 350)

1.8.8. Active barcode decoder

```
Decode ABCG
```

Indicates the active barcode symbologies in the terminal. Please refer to the following table.

| Axiome's reference | Symbology | Character set | Length | Check |
|--------------------|--------------------|---------------|--------|-------|
| A | EAN8 | numeric (0-9) | 7 | 1 |
| A | EAN13 | numeric (0-9) | 12 | 1 |
| A | EAN13 + 2 digits | numeric | 14 | 1 |
| A | EAN13 + 5 digits | numeric | 17 | 1 |
| B | CODE 39 | alphanumeric | 1 - 50 | - |
| C | 2 of 5 int. | numeric (0-9) | 1 - 50 | - |
| D | CODE 128 A B C | alphanumeric | 1 - 49 | 1 |
| E | CODE 93 | alphanumeric | 1 - 48 | 2 |
| F or J* | CODABAR | numeric (0-9) | 1 - 50 | - |
| G | UPC - E | numeric | 7 | 1 |
| G | UPC - E + 2 digits | numeric | 9 | 1 |
| G | UPC - E + 5 digits | numeric | 12 | 1 |
| H | Datalogic 2/5 | numeric (0-9) | 50 | - |

* Codabar with start / stop

For example: The terminal showing Decode ABCG can only decode the symbologies EAN, code 39, 2 of 5 interleaved and UPC.

1.8.9. Battery state

Battery 99%

Indicates in percent how far the battery is charged. A full charge on the base station from 0 % to 100 % take about 5h30m.

When the value arrived at 0%, the terminal will show "BATTERY EMPTY" and the key board is locked. In this state, the terminal will keep the data during 2 weeks without recharging. If you don't recharge the terminal during this time, you will loose the data, the user program and the firmware. To reactivate the terminal, you must proceed with a hard reset (see Chapter 4 :, page 25).

1.8.10. Terminal's number

BARman Nr 1 v

Indicates the number that has been attributed to the terminal with a communication program.

Remarks:

- A new terminal has always number 0.
- Each terminal connected to a BARman network MUST have a different number to be detected by the communication program.

1.8.11. Firmware version

```
unlock v7.6/0111
```

Indicates if the terminal is locked (a password has to be introduced before using) or unlocked (ready to be used).

Indicates the Terminal's firmware version (V7.6) as well as the RFID reading / writing head version (1.11) if present, otherwise you will find 4 dots after the slash.

There are two different types of RFID reading / writing head (TLT-1d and TLT-1e) for the t.BARman TAG / TBC. Please refer to the table below to see which head, which type of TAG can read / write.

| Manufacturer | Axiome ref. | Type of tag | Memory size | Read/Write | Firmware t.BARman / reader | TAG Reading head |
|--------------------------|-------------|-------------|-------------|------------|-----------------------------|------------------|
| EM Microelectronic-Marin | b | EM H4x02 | 64 bits | R | V7.6 / V1.11 | TLT-1d |
| EM Microelectronic-Marin | c | EM V4050 | 1 kbits | R / W | V7.6 / V1.11 | TLT-1d |
| EM Microelectronic-Marin | d | EM H4x05 | 128 bits | R | V7.6 / V1.11 | TLT-1d |
| MicroCID (see note 1) | e | UCID 1106 | 2 kbits | R / W | V7.6 / V1.11 | TLT-1d |
| Philips | g | Hitag 1 | 2 kbits | R / W | V7.6 / V1.11 & V7.6 / V3.03 | TLT-1d & TLT-1e |
| Sokymat | h | Nova | 160 bits | R / W | V7.6 / V3.03 | TLT-1e |
| Atmel | i | Temic 5550 | 264 bits | R / W | V7.6 / V3.03 | TLT-1e |
| Atmel | j | Temic 5551 | 264 bits | R / W | V7.6 / V3.03 | TLT-1e |
| Atmel | k | Temic 5552 | 992 bits | R / W | V7.6 / V3.03 | TLT-1e |

Note 1 : Also available at EM Microelectronic-Marin (ref. P4056)

1.8.12. Print

```
Print ? (+)
```

After selection of this item, with the "□+" key, the terminal start a print procedure on the serial port or goes off if there is no print procedure in its program.

1.9. Programming software

AXEL32 Extended is the programming language for BARman, BARman Laser and t.BARman. With it you can write a program for data collection according to your needs. The "AXEL32 Extended programming tool" is described in detail in volume 5.

1.10. Communication software

Axiome Alpha SA has developed several communication software, all based on the same communication protocol. Each communication software correspond to a well precise needs and cover so the complete possibility of the terminal connections.

1.10.1. AXS communication software for MS-DOS

AXS communication software has to be used with MS-DOS 3.1 or later versions. This software is composed of several independent programs covering all functions necessary to support a single terminal system or a large number of terminal units (max. 9999) together with a complete network.

Some of the AXS features are:

- interactive software with pull-down menus
- database monitoring of the system
- identification and time-setting of the connected terminal
- automatic downloading of tables, programs and messages to the terminal
- automatic uploading of data from the terminal to computer (TSR)
- setting of the configuration and data protection in case of power failure

The AXS software contains the following programs :

- AXMENU to initialize the terminal and their database
- AXPPROG to download the user's program to a terminal declared in the database
- AXPARAM to download parameter files to a terminal declared in the database
- AXREAD to upload stored data from each terminal declared in the database
- AXTSR Memory resident program to automatically upload stored data from each terminal declared in the database
- AXNOTTSR to unload AXTSR program

1.10.2. BARCOM for Windows (32 bits application)

BARCOM is a communication software for Windows 9x / NT / 2000 allowing the data transfer between a terminal laid on it's single interface (BEI or IBS) and a computer.

BARCOM can also be used in command line mode, from another program or from a batch file.

Furthermore, a scripting language is included into BARCOM in order to give an easy way to execute a list of commands.

Remark: BARCOM can not be used with a network of interfaces, as well as with concentrators CIU

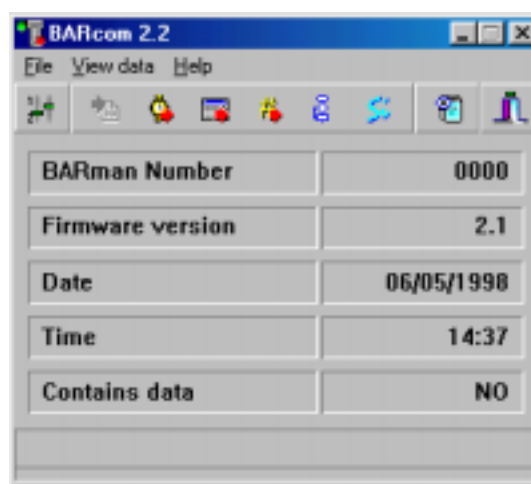

1.10.3. BARmanager for Windows (16 bits application)

BARmanager is communication and management software for Windows 3.1 (Windows 9x / NT compatible).

The object oriented technology allows a totally graphic visualization and management of the objects (BARman, program, etc...). BARmanager uses the "Drag & Drop" technique to transfer one object to another one.

For example :

to send a program to a BARman, you just have to click on the program Icon, than drag it and drop it on the BARman Icon.

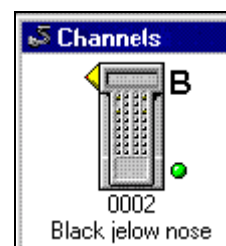

1.10.4. DDEServer for Windows (16 bits application)

DDEServer is a software allowing to a Windows 16 bits application an easy communication with the terminals. DDEServer is a software tool especially meant for the Windows applications developers (EXCEL, MS_ACCESS, PARADOX, Visual Basic, etc...) based on DDE links.

1.10.5. BAROLE for Windows (32 bits application)

BAROLE is a software allowing to a Windows 32 bits application an easy communication with the terminals BAROLE is a software tool especially meant for the Windows applications developers (EXCEL, MS_ACCESS, PARADOX, Visual Basic, etc...) based on objects programming.

Chapter 2 : Maintenance

2.1. Terminal's maintenance

To clean the terminal, just use a soft cloth moistened with tap water, and with mild soap is desired.

Dust particles may obstruct the opening of the terminal barcode reading head. To clean it, merely unscrew the cover of the reading head ("nose") and blow the dust out. Simply press the cover back in place to reinstall it.

The Ni-MH battery of your terminal will operate for several years. It must be replaced when the message "BATTERY DEFECT" appears regularly on the display. The battery must be replaced by an authorised dealer.

2.2. " Left-handed " reading heads

For left-handed user, it is possible to place the barcode reading head and/or the RFID reading / writing head to the right of the terminal's display.

This modification should only be performed by an authorised dealer.

Chapter 3 : Troubleshooting

3.1. Error messages in BARman

Several error messages may appear on the terminal's display.

| Error messages | Remedy |
|---|---|
| <p><u>Memory full</u> The terminal's memory cannot accept further information.</p> | Transfer the terminal's data into the computer before using again. |
| <p><u>Battery empty</u> The terminal's battery is empty; this status freeze the keypad.</p> | Your terminal can be unfreezed by placing it on its base station for at least 4 minutes. Total recharge will take 5 1/2 h. |
| <p><u>Battery defect</u> The terminal was a long time out of its base station.</p> <p>or</p> <p>The terminal's battery is worn out.</p> | Recharge it. Ask your authorised dealer to replace it immediately. |
| <p><u>Function error</u> Function called is not present.</p> | Check firmware and compiler version. |
| <p><u>Format error</u> The table has an incorrect format.</p> | Check your table for unacceptable characters. |
| <p><u>Program error</u> No program present.</p> <p>or</p> <p>Program overlaps the firmware</p> | Download a program to the terminal. Compile the program at a higher address |
| <p><u>Table error</u> Bad number of tables or no table declared in the program.</p> | Download all the tables or verify the program. |
| <p><u>Memory error</u> Program or table out of memory.</p> | Scale down the program or the tables. |
| <p><u>Memory not empty</u> Memory contains data.</p> | Upload data to the computer. |
| <p><u>The terminal does not work any more, keyboard does not respond, no more communication;</u> Programming error, battery low after long period without recharging.</p> | Try to retrieve data with the tools "BARrecover" available on our web site (www.axiome.ch) or by your dealer else, program and data are lost ! Do a HARD RESET ! See Chapter 4 .: |

Chapter 4 : Hard Reset

IMPORTANT

The Hard Reset on a terminal should only be effected in case there is no other solution (for example in case the terminal has not been recharged for more than 2 months).

**When you carry out a Hard Reset,
all the data and parameters will be lost !**

4.1. Terminal's Hard Reset

- Remove the plastic cap from the back of the terminal (bottom arrow).
- To carry out a hard reset, make an electrical bridge with a paper clip between the contact disc and the magnetic contact on the circuit (13 mm inside the whole). Once the paper clip is removed, the terminal emits a bip.
- **You have now 30 seconds to transfer the firmware.**

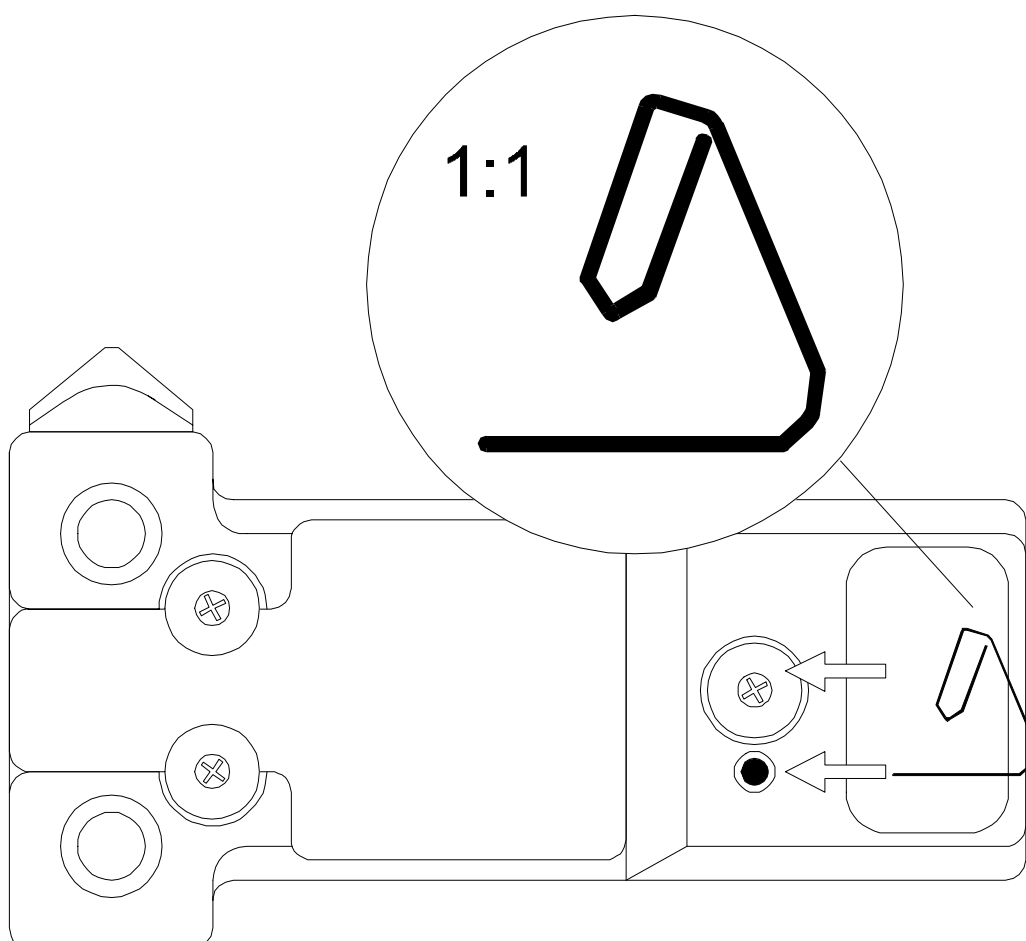

4.2. Firmware transfer under MS-DOS

Execute the FIRMnn_X.BAT batch.

The X in the command is the number of the serial communication port of your PC (COM) and nn is the release number of the firmware.

This batch copies the data from the terminal into a file and sends to it the Hex file of the firmware.

Remark:

The necessary files for this transfer are in the BARMAN directory of the P.C. to which your terminal is connected. The last firmware version of the terminal (Bxxxabcg.exe) is available on Axiome's web site www.axiome.ch.

4.3. Firmware transfer under Windows

The transfer of the firmware (after a Hard Reset) under Windows can be made with the "Terminal" communication program, delivered in standard together with Windows. The Hex file of the firmware is in the BARMAN directory of the PC. to which your terminal is connected. A help document (Firmhelp.exe) is available at your reseller or on Axiome's web site www.axiome.ch.

The users of BARmanager communication software are able to download a firmware to the terminal, only when the terminal works and is connected to a single interface (BEI, IBS or BIU). If a hard reset has been done on the terminal, the firmware must be transferred as explained above.

With the BARCOM communication software it is very easy to download the firmware into the terminal, using the "Firmware update" command in the "File" menu.

Appendix A: BARman ATL with 17 keys front (series 100)

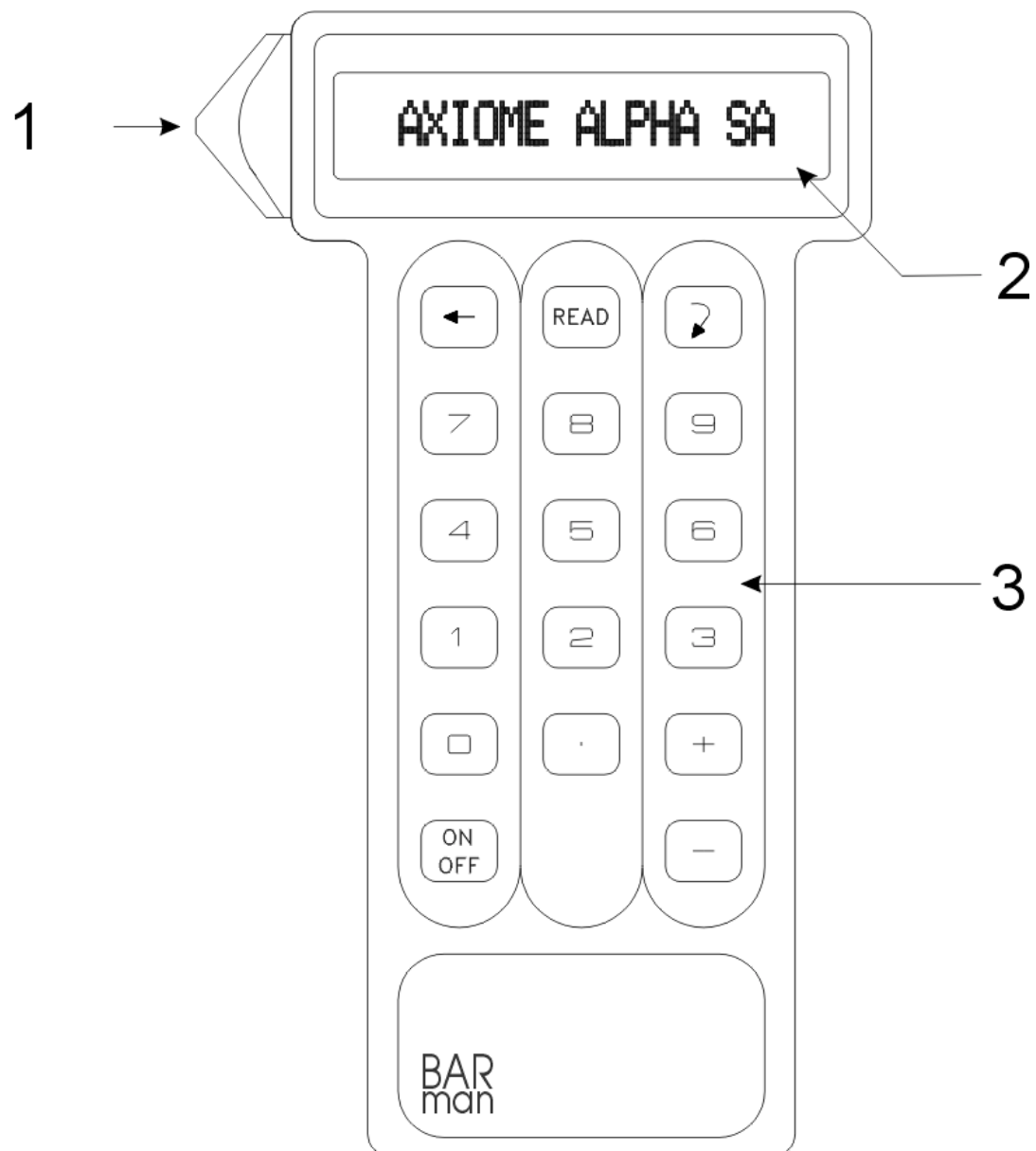

Appendix B: BARman ATL with 34 keys front (series 300)

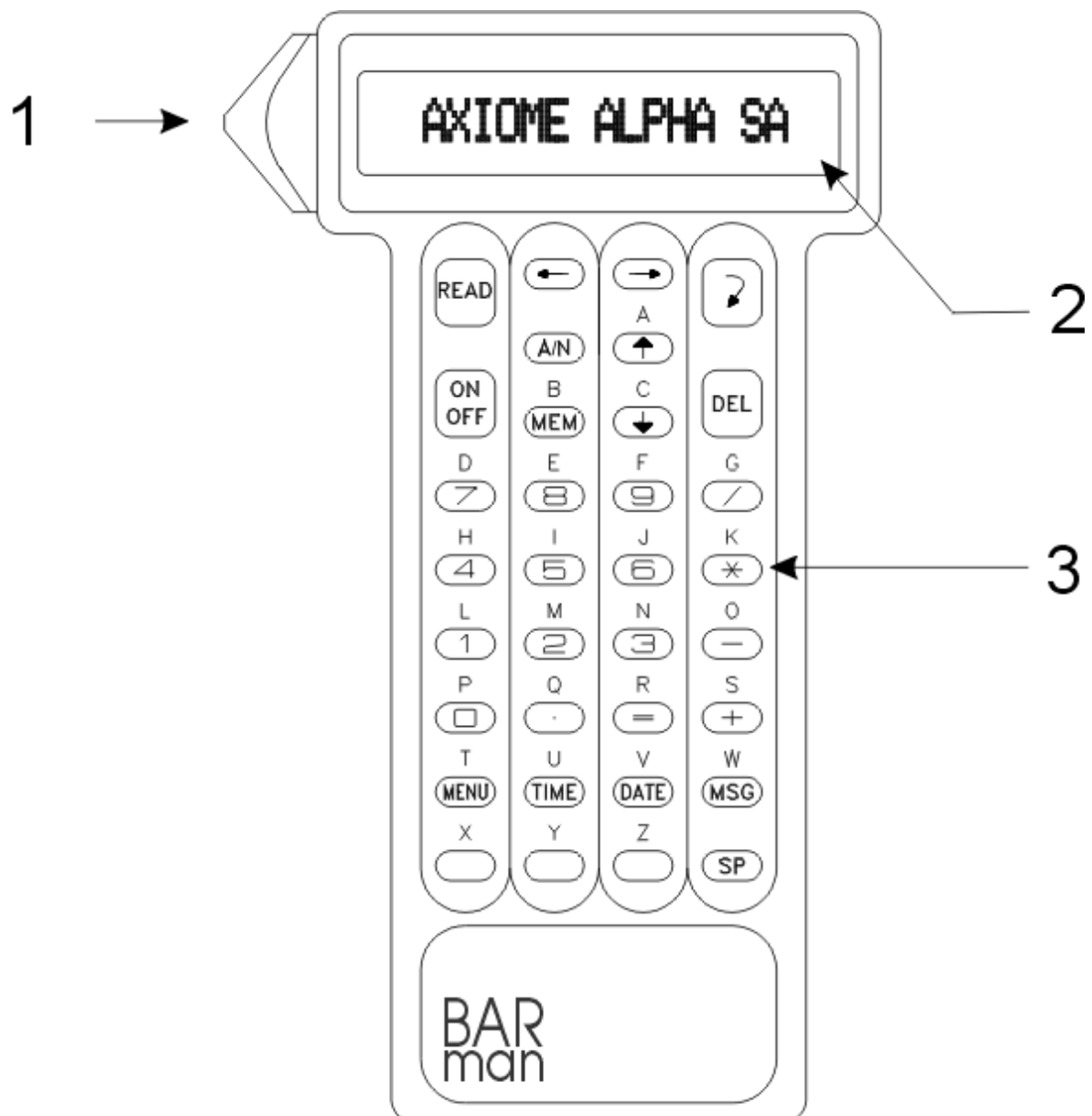

Appendix C: t.BARman TAG with 17 keys front (series 100)

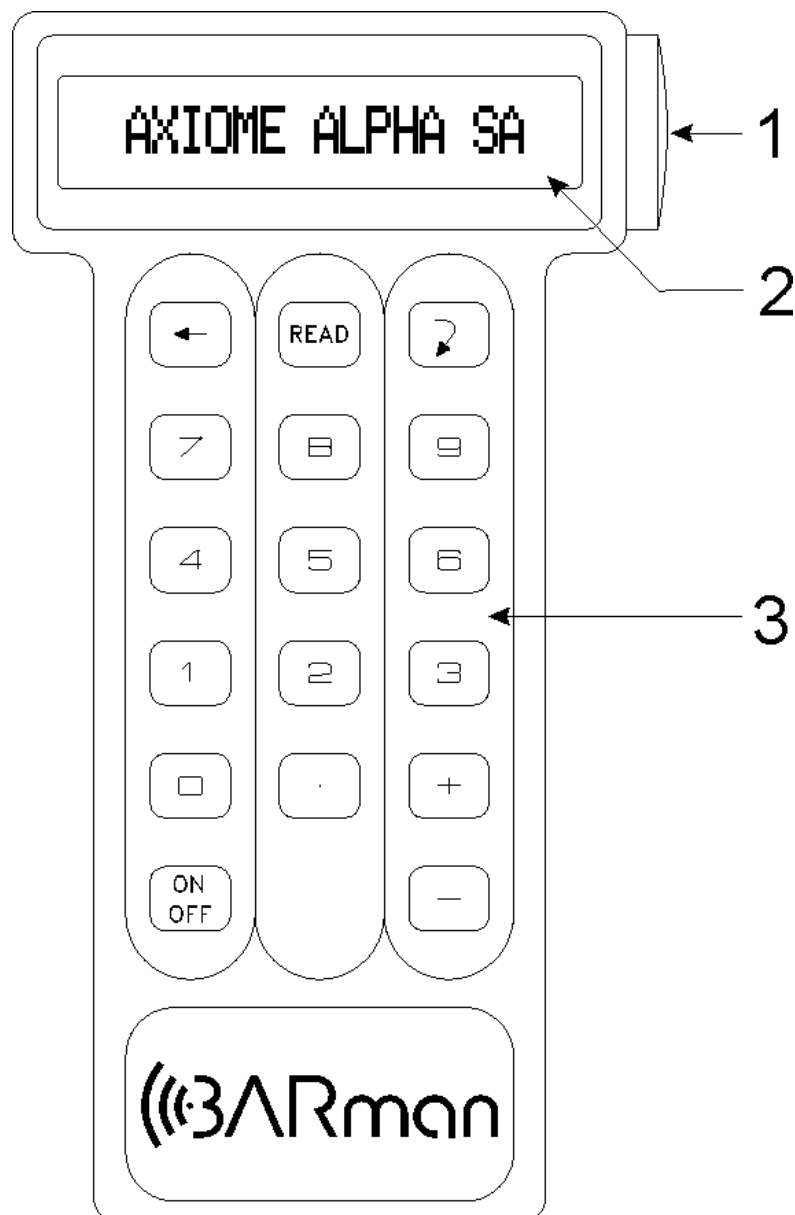

Appendix D: t.BARman TAG with 34 keys front (series 300)

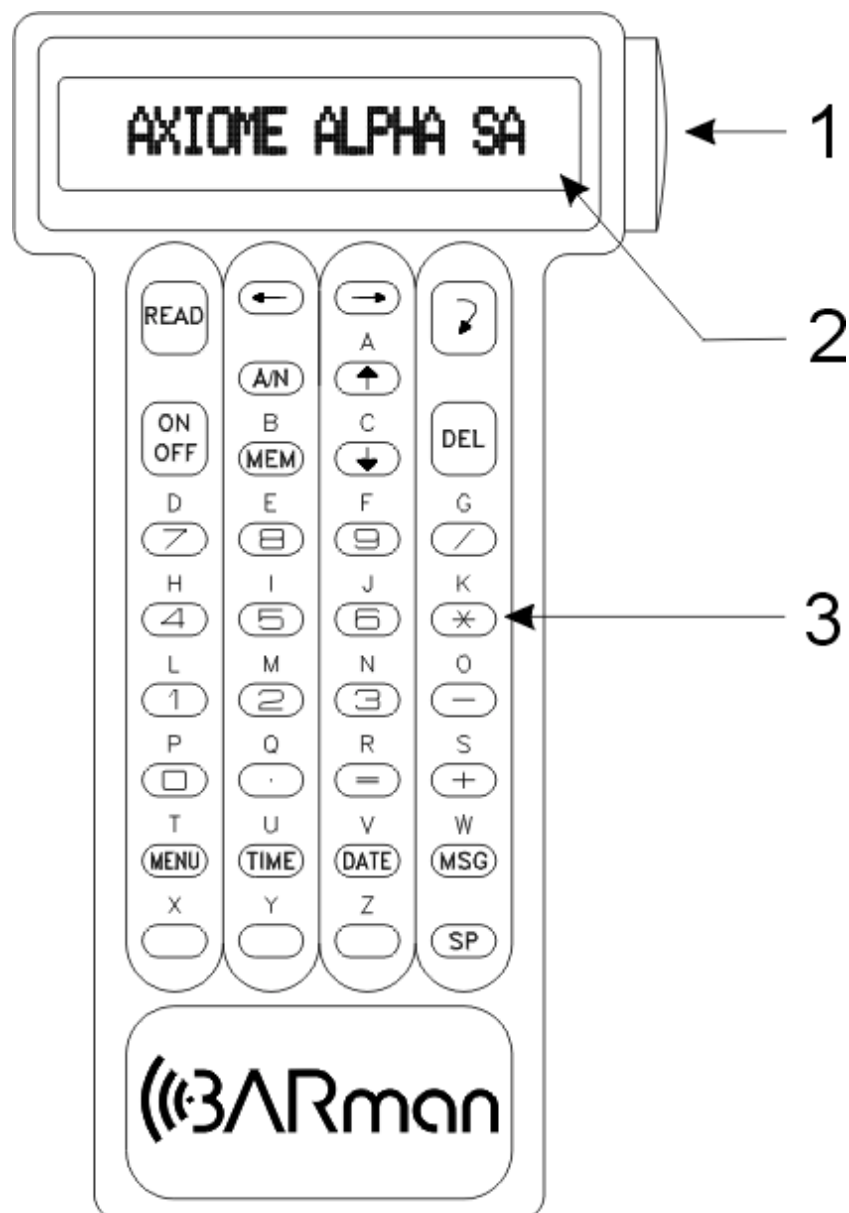

Appendix E: t.BARman TBC with 17 keys front (series 100)

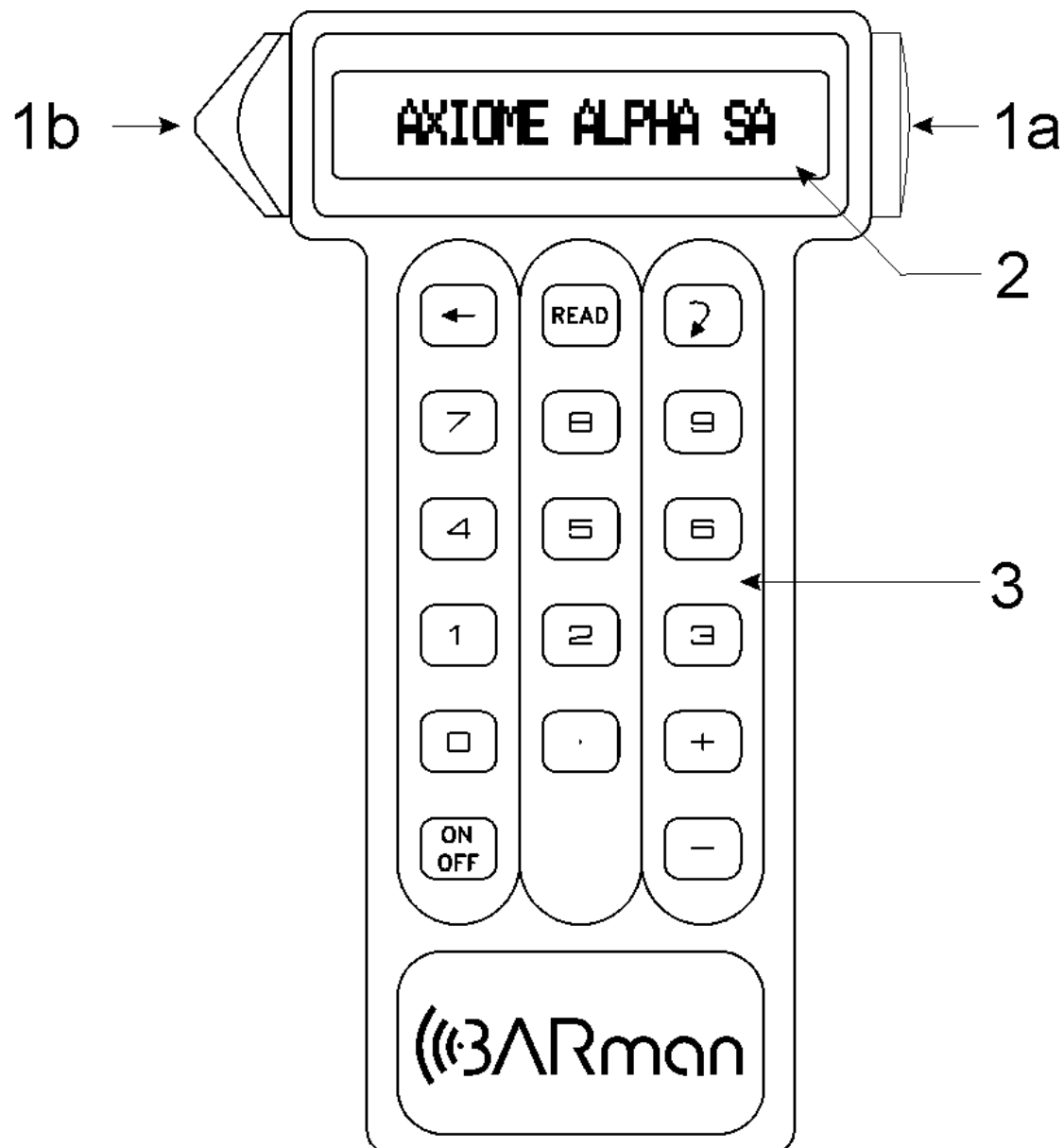



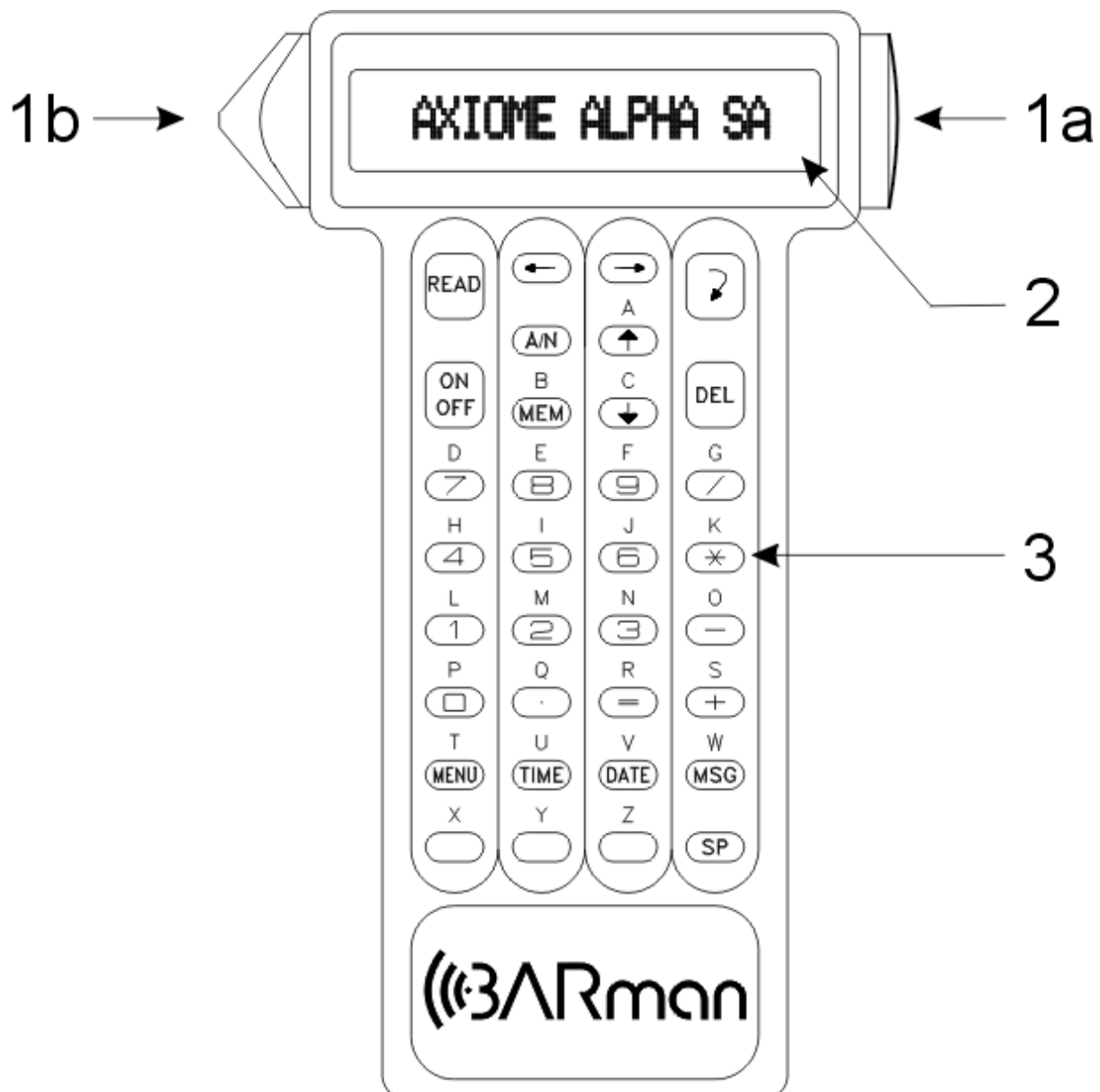



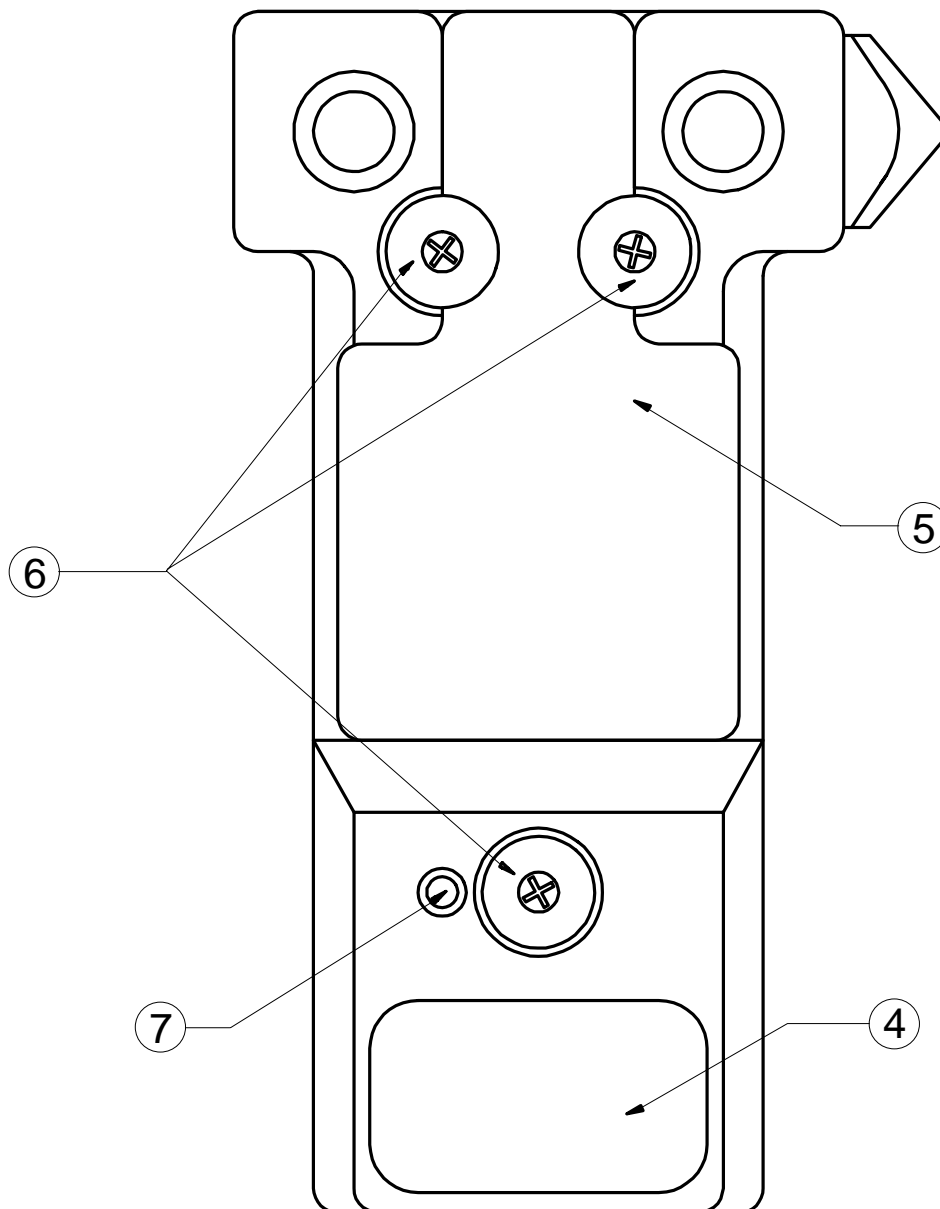





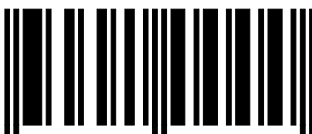

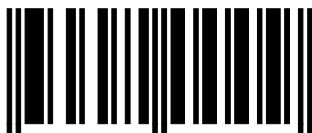
Appendix F: t.BARman TBC with 34 keys front (series 300)

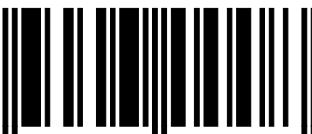
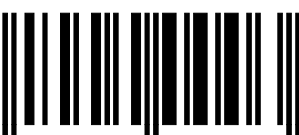

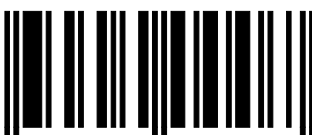
Appendix G: Terminal's back (series 100 & 300)



Appendix H: Table for Demo 6 and Demo 8 AXEL program

| Activity | Employee | Goods |
|---|---|--|
|  |  |  |
| ARRIVAL | Smith S. | Flour |
|  |  |  |
| BREAD | Mueller K. | Salt |
|  |  |  |
| PASTRY | Dupond J. | Sugar |
|  |  |  |
| SALES | Fernandez | Chocolate |
|  |  | |
| DEPARTURE | Rossi M. | |
|  | | |
| CANCEL | | |
|  | | |
| STOCK IN | | |
|  | | |
| STOCK OUT | | |



Identification et saisie de données
Identification and data capture

Axiome Alpha SA
1, rue du Chasselas
CH-2034 Peseux, Switzerland

Tel. +41 (0)32 732 18 18
Fax. +41 (0)32 732 18 00

Web site: <http://www.axiome.ch>
e-mail: info@axiome.ch

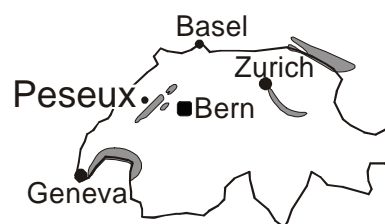

Axiome Alpha GmbH
Justus-v.-Liebig-Str. 2
D-85435 Erding, Germany

Tel. +49 (0)8122 88095 0
Fax. +49 (0)8122 88095 10

Web site: <http://www.axiome.de>
e-mail: info@axiome.de

